

Short Form Specifications for:

4"- 12" SDR 26 HW Molded Gasketed Sewer Fittings

Tigre's SDR 26 HW Molded Gasketed Sewer fittings are manufactured using a custom formulated virgin PVC compound with a cell classification of 12454 or 13343 in accordance with, and certified by the National Sanitation Foundation (NSF), to meet ASTM D 1784.

Tigre's SDR 26 HW Molded Gasketed Sewer fittings are manufactured in accordance with ASTM D 3034, ASTM F 1336.

The gasketed joints conform to ASTM D 3212 (Internal Pressure Test and Vacuum Test) which meet all of the requirements of ASTM F 477 or ASTM F 913.



Multiple-Plane Reinforced Rib Fitting

Tigre's SDR 26 HW Molded Gasketed Sewer fittings have reinforced ribs, which provide a higher stiffness, higher over bellng resistance and a ramp design for a better material flow and more fitness at transition points.

Improved Flow Characteristics

Molds for Tigre's SDR 26 HW Molded Gasketed Sewer fittings are designed to produce a completely smooth interior and eliminate any "knit" lines that could impede the flow or collect debris.

UPC and Bar Code Labeling

To facilitate accuracy and speed up inventory counts, all boxes are labeled with unique, industry standard UPC bar codes.



Superior in Design and Performance

SDR 26 Gasketed Piping Systems Engineered to Fit Every Time

We not only meet, but we tighten the industry standard dimensional tolerances to insure a perfect fit between the pipe and fittings, every time.

Product Reliability

For over 60 years, Tigre has manufactured and supplied PVC pipe and fittings to the water works industry. We have developed a longstanding reputation of providing the highest quality, defect-free products available on the market.

Bell End Dimensional Data (Inches)

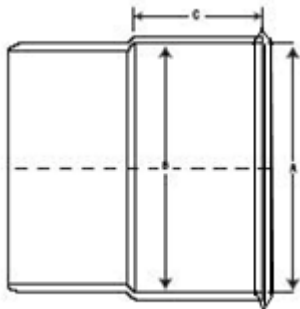

Size (In)	A*	B*	C**
4"	4.240	4.209	1.500
6"	6.309	6.270	2.170
8"	8.435	8.388	2.520
10"	10.545	10.485	2.920
12'	12.554	12.482	3.190

* Average dimension ** Minimum dimension

Tolerances of Product specifications are applicable to nominal dimensions. The drawings are provided to show approximate profile scheme.

The information in this document is given as a guideline only and is subject to change without notice.

For more details please contact Tigre USA Inc.